

The 6-31B(d) Basis Set and the BMC-QCISD and BMC-CCSD Multicoefficient Correlation Methods

Benjamin J. Lynch, Yan Zhao, and Donald G. Truhlar*

Department of Chemistry and Supercomputer Institute, University of Minnesota,
Minneapolis, Minnesota 55455-0431

Received: September 14, 2004; In Final Form: December 13, 2004

Three new multicoefficient correlation methods (MCCMs) called BMC-QCISD, BMC-CCSD, and BMC-CCSD-C are optimized against 274 data that include atomization energies, electron affinities, ionization potentials, and reaction barrier heights. A new basis set called 6-31B(d) is developed and used as part of the new methods. BMC-QCISD has mean unsigned errors in calculating atomization energies per bond and barrier heights of 0.49 and 0.80 kcal/mol, respectively. BMC-CCSD has mean unsigned errors of 0.42 and 0.71 kcal/mol for the same two quantities. BMC-CCSD-C is an equally effective variant of BMC-CCSD that employs Cartesian rather than spherical harmonic basis sets. The mean unsigned error of BMC-CCSD or BMC-CCSD-C for atomization energies, barrier heights, ionization potentials, and electron affinities is 22% lower than G3SX(MP2) at an order of magnitude less cost for gradients for molecules with 9–13 atoms, and it scales better (N^6 vs N^7 where N is the number of atoms) when the size of the molecule is increased.

1. Introduction

Multicoefficient correlation methods^{1–6} (MCCMs) have proven to be a very efficient means for the computation of thermochemical properties. MCCMs use a linear combination of ab initio wave function methods to extrapolate to the exact nonrelativistic Born–Oppenheimer solution to the Schrödinger equation. Many MCCM methods, such as multicoefficient QCISD⁶ (MC-QCISD/3), multicoefficient G3⁶ (MCG3/3), G3-Scaled^{5,6} (G3S/3), G3S-Extended⁷ (G3SX), and reduced-order G3SX⁷ (G3SX(MP2) and G3SX(MP3)), use a large one-electron basis set for uncorrelated and less-correlated components (Hartree–Fock (HF) and Møller–Plesset (MP) second-order perturbation theory⁸ (MP2), respectively) and a small one-electron basis set for components that include a large amount of electron correlation (quadratic configuration interaction with single and double excitations⁹ (QCISD), and QCISD with quasiperturbative triples,⁹ QCISD(T)).

Current MCCM methods utilize previously constructed basis sets, and simultaneously extrapolate to full electron correlation and a complete one-electron basis set. Although larger basis sets usually give more accurate energies in single-level approaches, there is no guarantee that a linear combination of energies will improve as one improves the basis sets. Previous studies¹⁰ have noted that an arbitrary improvement of one of the basis sets in a MCCM can lead to an inferior method, even when the extrapolation coefficients are re-optimized for the new basis set. In fact, this phenomenon was pointed out¹¹ years ago in the context of scaling all correlation energy (SAC), where it was emphasized that a basis set useful for such extrapolation must be “correlation balanced.” With this in mind, in the present article, we developed three new MCCM methods that employ a new basis set designed to have optimal extrapolation properties.

Previous studies^{6,12} have shown that the QCISD level of electron correlation is a minimal level for achieving reliable extrapolations of the electron correlation energy, and this work led to the development of MC-QCISD.¹² Extrapolation with lower levels such as MP2 and fourth-order MP perturbation theory with single double and quadruple excitations (MP4-(SDQ)) is more accurate and less expensive than not extrapolat-

ing,^{2,6,13} but it is not as reliable as extrapolation methods that include at least one calculation with QCISD or better.^{6,12,14} MC-QCISD has been shown to be a highly efficient MCCM method, and this is why it is the starting point of the new method developed here. However, it is well-known that there are some cases^{15–18} where coupled cluster theory with single and double excitations (CCSD) performs significantly better than QCISD. Therefore, we also report a version of the theory in which the coefficients are optimized for CCSD instead of QCISD.

Section 2 discusses the experimental database used, section 3 describes the optimization of the new method and basis set, section 4 gives the results and discussion, and section 5 is a summary.

2. Methods and Experimental Database

The theoretical methods used in the present study include HF, MP2, MP fourth-order perturbation theory with double and quadruple excitations¹⁹ (MP4(DQ)) or with single, double, and quadruple excitations¹⁹ (MP4(SDQ)), coupled-cluster theory with singles and doubles (CCSD),^{9,20} CCSD with quasiperturbative connected triples²⁰ (CCSD(T)), and full configuration interaction^{21,22} (FCI). For all correlated ab initio methods, the core orbitals are doubly occupied in all configurations. For full CI calculations, all virtual orbitals are included. FCI calculations were performed with MOLPRO,²³ and the remainder of the calculations were performed with Gaussian98²⁴ and Gaussian03.²⁵

In addition to the new 6-31B(d) basis set described in section 3, this paper uses the following other basis sets: 6-31G(d),¹⁹ 6-31G(2df,p),¹⁹ G3Large,²⁶ MG3,^{4,27} MG3S,¹⁰ and G3XLarge.⁷

A new test set was created for the present work. It consists of 273 data and is named Database/4. We optimized the basis sets and MCCM coefficients for this paper using Database/4HM, which is identical to Database/4 except that it also includes the electron affinity for H. It contains 160 atomization energies (AEs), 36 electron affinities (EAs), 36 ionization potentials (IPs), and 42 barrier heights (BHs). We note 177 data are from Database/3,⁶ and the 97 new data are described below. All data in Database/4 are zero-point exclusive; i.e., zero-point contributions to the energy have been removed from the experimental

TABLE 1: Zero Point Energy (kcal/mol): Accurate Value and Values Computed Using Four Sets of Frequencies

| molecule | anharmonic ZPE ^a | MP2/cc-pVDZ unscaled | MP2/cc-pVDZ scaled ZPE ^b | exp fundamentals ^a | scaled exp fundamentals ^c |
|-------------------------------|-----------------------------|----------------------|-------------------------------------|-------------------------------|--------------------------------------|
| H ₂ | 6.21 | 6.43 | 6.30 | 6.29 | 6.43 |
| CH ₄ | 27.71 | 28.49 | 27.89 | 27.11 | 27.69 |
| NH ₃ | 21.20 | 21.85 | 21.39 | 20.63 | 21.07 |
| H ₂ O | 13.25 | 13.57 | 13.29 | 12.88 | 13.15 |
| HF | 5.85 | 5.96 | 5.84 | 5.92 | 6.04 |
| CO | 3.11 | 3.02 | 2.96 | 3.10 | 3.17 |
| N ₂ | 3.36 | 3.11 | 3.04 | 3.37 | 3.44 |
| F ₂ | 1.30 | 1.33 | 1.31 | 1.31 | 1.34 |
| C ₂ H ₂ | 16.46 | 16.55 | 16.20 | 16.18 | 16.53 |
| HCN | 9.95 | 9.93 | 9.72 | 9.76 | 9.97 |
| H ₂ CO | 16.53 | 16.87 | 16.52 | 16.14 | 16.48 |
| CO ₂ | 7.24 | 7.24 | 7.09 | 7.17 | 7.32 |
| N ₂ O | 6.77 | 6.74 | 6.59 | 6.70 | 6.84 |
| RMSE | | 0.33 | 0.17 | 0.29 | 0.10 |

^a Reference 2, based on Martin, J. M. L. *J. Chem. Phys.* **1992**, 97, 5012. ^b Scaling factor of 0.979. ^c Scaling factor of 1.021.

values so that the values in the database can be directly compared to calculated theoretical electronic energies (including nuclear repulsion). All data in Database/4 are for main group elements; transition metals are not considered.

For electron affinities and ionization potentials, we start with the experimental IP or EA. Zero-point-exclusive EAs and IPs are determined by removing the ZPE calculated using mPW-1PW91/MG3 frequencies scaled¹⁰ by 0.9758. The zero-point-exclusive EAs and IPs in Database/4 are listed in Supporting Information. Database/4 includes 13 IPs from Database/3 and new experimental IPs for Li,²⁸ Be,²⁸ B,²⁸ N,²⁸ F,²⁸ Na,²⁸ Mg,²⁸ Al,²⁸ Cl,²⁸ AlO,²⁹ NH₃,²⁹ CN,³⁰ Na₂,²⁹ O₃,²⁹ CF,²⁹ CH₃,²⁹ Al₂,³¹ SiH,²⁹ FO,³² PO,²⁹ AlF,³³ NaLi,³⁴ and MgCl.³⁵ Database/4 includes 13 EAs from Database/3 and new experimental EAs for H,³⁶ Li,³⁶ B,³⁶ F,³⁶ Na,³⁶ Al,³⁶ AlO,³⁷ NH,³⁶ CN,³⁶ CH,³⁶ CH₂,³⁶ O₃,³⁶ LiCl,³⁶ NaF,³⁶ SiH,³⁶ MgCl,³⁶ Na₂,³⁶ HNO,³⁶ MgH,³⁶ Al₃,³⁸ FO,³⁶ PO,³⁶ and BeH.³⁶ We note that PO⁻ is described as a ground state singlet elsewhere;³⁶ however, with careful SCF convergence one will predict that it is a ground state triplet, which agrees with experiment.³⁹ All 42 barrier heights used in Database/4 are unchanged from Database/3.

We include the 109 atomization energies from Database/3 and the atomization energy for the following 51 additional systems: LiH,²⁸ BeH,³⁰ Li₂,³⁰ BeLi,⁴⁰ BH₃,³⁵ B₂,⁴¹ LiO,³⁰ BC,⁴² NaH,⁴³ LiF,³⁰ LiOH,³⁵ BeO,⁴⁴ MgH,³⁰ BeF,⁴⁵ BeOH,⁴⁶ BO,⁴⁷ AlH,⁴⁸ BF,³⁰ FO,³⁵ LiCl,³⁰ NaF,³⁵ NaOH,⁴⁴ MgO,⁴⁴ PC,⁴⁹ AlO,⁵⁰ BeCl,³⁵ MgF,³⁵ MgOH,⁵¹ N₂O,²⁸ HCP,⁵² Na₂,³⁵ AlF,³⁵ NaLiO,⁴⁴ BeF₂,³⁵ Be(OH)₂,⁴⁴ NO₂,²⁸ PO,³⁵ (C₂H₄)NH,²⁸ O₃,²⁸ NaCN,³⁵ NCCN,²⁸ Al₂,⁵³ NaCl,³⁵ MgS,⁵⁴ MgCl,⁵⁵ PO₂,⁵⁶ ClNO,²⁸ CH₃-CONH₂,²⁸ ClNO₂,³⁵ BCl₂,³⁵ and SF₆.²⁷

When available, the starting D_0 or D_e value is taken from the references in the previous paragraph; in most of the remaining cases we begin with the experimental $\Delta H_{f,298}^\circ$ and use the procedure described elsewhere² to obtain the zero-point exclusive atomization energy (D_e). The D_e for a few systems were determined in system-specific ways, as follows: We updated our D_e for CH₂ (³B₁) from the experimental⁵⁷ D_0 of 753.3 kJ/mol and the anharmonic ZPE⁵⁸ of 3736.4 cm⁻¹ giving a D_e of 190.72 kcal/mol. We obtained an updated D_e for CH₂ (¹A₁) of 181.37 kcal/mol from the D_e of CH₂ (³B₁), the experimental singlet–triplet splitting (T_0) of 3147 cm⁻¹,⁵⁹ and the anharmonic ZPE⁵⁸ of 3612.0 cm⁻¹ for CH₂ (¹A₁). We updated the D_e for NO using the experimental heat of formation,³⁵ thermal corrections calculated with MP2/cc-pVDZ frequencies scaled by 0.979, and the experimental zero-point

TABLE 2: Spin-Orbit Coupling Stabilization Energy (kcal/mol)

| system | ΔE_{S-O} | system | ΔE_{S-O} |
|-----------------|------------------|-----------------|------------------|
| B | -0.03 | Cl ⁺ | -1.05 |
| C | -0.09 | B ⁻ | -0.02 |
| O | -0.23 | O ⁻ | -0.16 |
| F | -0.38 | Al ⁻ | -0.18 |
| Al | -0.21 | P ⁻ | -0.28 |
| Si | -0.43 | S ⁻ | -0.55 |
| S | -0.56 | CH | -0.04 |
| Cl | -0.84 | OH | -0.20 |
| C ⁺ | -0.13 | NO | -0.18 |
| N ⁺ | -0.27 | FO | -0.28 |
| F ⁺ | -0.42 | SH | -0.54 |
| Si ⁺ | -0.58 | ClO | -0.46 |
| P ⁺ | -0.90 | Si ₂ | -0.20 |

energy³⁰ of 2.71 kcal/mol to give a D_e of 152.05 kcal/mol. We updated the D_e for C₂F₄ to be the average of two experiments.^{35,60}

To aid in the accurate prediction of D_e for CCH and MgCl, we optimized a general scaling factor for fundamental frequencies to obtain accurate ZPEs. Table 1 gives the anharmonic ZPE² and the ZPE predicted by four other methods. The scaling factor for MP2/cc-pVDZ ZPE was found in a previous study² and has been used for many data in Database/4. However, for some systems, especially those with high spin contamination, the MP2/cc-pVDZ frequencies are much higher than experiment. Therefore, we optimized a scaling factor that relates experimental fundamental frequencies² to the anharmonic ZPE. The scaling factor we obtain is 1.021. Using this new scale factor and the experimental fundamental frequencies³⁵ for CCH, we obtain an improved D_e of 265.13 kcal/mol to replace the previous value of 267.83 kcal/mol. For MgCl, we use the experimental⁵⁵ D_0 and the fundamental frequency to obtain a D_e of 76.44.

Our calculations explicitly include spin–orbit coupling for all calculations where it is not zero by symmetry; these atoms, ions, and molecules found in Table 2. (Therefore, spin–orbit contributions are not removed from the database values.) The spin–orbit coupling values in Table 2 come from previous collections.^{2,30,61} All values tabulated are the stabilization of the ground state using the Russell–Saunders scheme.

The average number of bonds for molecules in the atomization database of Database/4 is called N_{bonds} and equals 3.775, where we count double and triple bonds as one bond, not 2 or 3. To make average errors more comparable over various databases and to provide the reader with a more physical characterization of the accuracy of the results, we compare the mean unsigned error per bond (MUEPB) by dividing the mean

unsigned error (MUE) in atomization energies by the mean number of bonds.

The complete Database/4 and Database/4HM are given in Supporting Information and on our Database web site.⁶²

3. Optimization of the New Method

The structures used here for all systems are geometries optimized by QCISD/MG3. Although we choose to use these geometries for all calculations in this paper, this level of theory is not an intrinsic part of the new method developed here. These geometries were chosen to adequately assess the electronic energies of different methods without the need to embark on a lengthy interpretation of the effect of cancellation of errors that can occur when using lower level geometries. All results in this article, including those obtained with G3SX, G3SX(MP3), and G3SX(MP2), will use the QCISD/MG3 geometries. We use the convenient shorthand notation //QM when necessary to specify this geometry to avoid confusion; this is required only for methods that are standardly defined to use other geometries.

In all cases, calculations are based on the lowest energy geometry (conformation). For example, for *n*-butane we use the anti conformation (not the gauche).

The new methods developed are based on MC-QCISD/3. Figure 1 illustrates the basis sets and levels of theory used in a MC-QCISD/3 calculation. The corresponding energy expression for MC-QCISD is

$$E(\text{MC-QCISD}/3) = E(\text{HF}/6\text{-}31\text{G}(\text{d})) + c_1\Delta(\text{HF}/\text{MG3S}|6\text{-}31\text{G}(\text{d})) + c_2\Delta(\text{MP2}|\text{HF}/6\text{-}31\text{G}(\text{d})) + c_3\Delta(\text{MP2}|\text{HF}/\text{MG3S}|6\text{-}31\text{G}(\text{d})) + c_4\Delta(\text{QCISD}|\text{MP2}/6\text{-}31\text{G}(\text{d})) + E_{\text{SO}} \quad (1)$$

where we use the pipe notation (“|”) introduced elsewhere¹⁴ to describe the energy differences that are scaled. The new BMC-QCISD method developed here differs from MC-QCISD/3 in three respects. First, it uses a modified extrapolation scheme which scales the MP4(SDQ) energy increment separately, as shown in Figure 2. Second, it replaces the MG3S basis with the MG3 basis. Finally, it uses a new basis set named 6-31B(d) in place of 6-31G(d). The energy expression for BMC-QCISD is given in

$$E(\text{BMC-QCISD}) = E(\text{HF}/6\text{-}31\text{B}(\text{d})) + c_{\text{H}}\Delta(\text{HF}/\text{MG3}|6\text{-}31\text{B}(\text{d})) + c_1\Delta(\text{MP2}|\text{HF}/6\text{-}31\text{B}(\text{d})) + c_2\Delta(\text{MP2}|\text{HF}/\text{MG3}|6\text{-}31\text{B}(\text{d})) + c_3\Delta(\text{MP4SDQ}|\text{MP2}/6\text{-}31\text{B}(\text{d})) + c_4\Delta(\text{QCISD}|\text{MP4SDQ}/6\text{-}31\text{B}(\text{d})) + E_{\text{SO}} \quad (2)$$

The new method, named BMC-QCISD, uses the same number of extrapolation coefficients as MC-QCISD. The coefficient c_{H} comes from

$$c_{\text{H}} = \frac{E_{\text{H}} - E_{\text{H}}[6\text{-}31\text{B}(\text{d})]}{E_{\text{H}}[\text{MG3}] - E_{\text{H}}[6\text{-}31\text{B}(\text{d})]} \quad (3)$$

where E_{H} is the energy for hydrogen atom.

The 6-31B(d) basis set is based on 6-31G(d). The basis set exponent for the most diffuse valence function and the polarization function is optimized for each atom. For hydrogen, this means optimizing the most diffuse s-function. For the remaining atoms, this meant changing the exponent of the most diffuse sp-set and the exponent of the d function for each atom. The

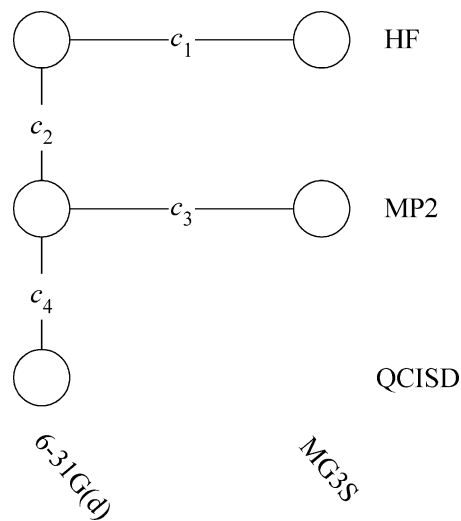

Figure 1. Coefficient tree for MC-QCISD/3.

objective function minimized is a weighted sum of the squares of the errors for the 274 data described in section 2, and is

$$\text{UF} = \sqrt{\sum_{i=1}^{274} w_i (E_{\text{calc}} - E_{\text{exp}})^2} \quad (4)$$

$$w_i = \frac{1}{6N_{\text{EA}}} \quad \text{for electron affinities} \quad (5)$$

$$w_i = \frac{1}{6N_{\text{IP}}} \quad \text{for ionization potentials} \quad (6)$$

$$w_i = \frac{1}{3N_{\text{BH}}} \quad \text{for barrier heights} \quad (7)$$

$$w_i = \frac{1}{3N_{\text{AE}}\bar{N}_{\text{bonds}}^2} \quad \text{for atomization energies} \quad (8)$$

where N_{EA} is the number of electron affinity data, N_{IP} is the number of ionization potential data, N_{BH} is the number of barrier height data, and N_{AE} is the number of atomization energy data. Thus the objective function places 33% weight on bond energies, 33% on barrier heights, and 17% each on ionization potentials and electron affinities. The optimized basis functions for the 6-31B(d) basis set are listed in Table 3, and the scaling coefficients are in Table 4. The exponents for the basis functions were optimized simultaneously with the four extrapolation coefficients. The basis functions were optimized using a genetic algorithm, and the optimal extrapolation coefficients (c_1 , c_2 , c_3 , c_4) were found at each step from the solution to the system of linear equations that minimize the error expression. Each basis function was allowed to vary by as much as a factor of 2 from its corresponding coefficient in the 6-31G(d) basis set. After we were satisfied that the genetic algorithm was converged, the parameters were varied to confirm that it was a minimum.

A very similar theory to QCISD⁹ is CCSD. CCSD^{63,64} includes all of the interactions of QCISD and a few additional interactions that have a minimal effect on the cost.⁶⁵ In fact, QCISD may be viewed as an approximation to CCSD. A main advantage of QCISD over CCSD in previous work was the wider availability of analytic gradients for QCISD than for CCSD. Because low-cost analytic gradients at the CCSD level are now more widely available, we wanted to use this theory as the basis for a method very similar to BMC-QCISD. The

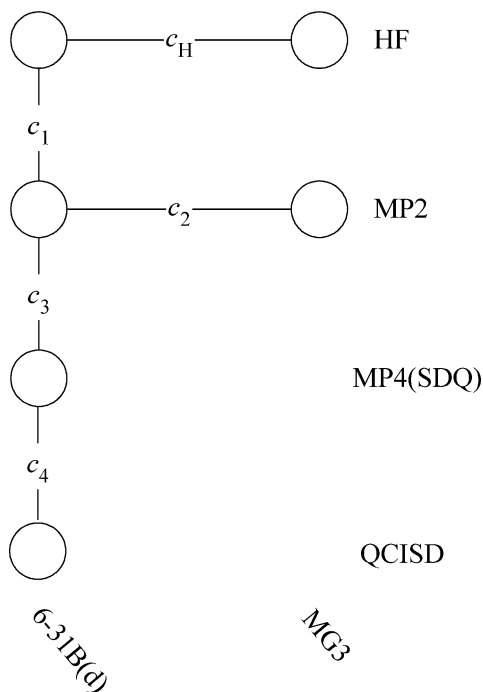

Figure 2. Coefficient tree for BMC-QCISD.

TABLE 3: Exponential Parameters for the 6-31G(d) and 6-31B(d) Basis Sets

| atom | valence sp | | d function | |
|------|------------------------|--------------------|------------|----------|
| | 6-31G(d) | 6-31B(d) | 6-31G(d) | 6-31B(d) |
| H | 0.1612778 ^a | 0.139 ^a | | |
| Li | 0.0359620 | 0.018 | 0.200 | 0.1000 |
| Be | 0.0823099 | 0.060 | 0.400 | 0.2450 |
| B | 0.1267512 | 0.168 | 0.600 | 0.4700 |
| C | 0.1687144 | 0.162 | 0.800 | 0.7000 |
| N | 0.2120313 | 0.180 | 0.800 | 0.7500 |
| O | 0.2700058 | 0.237 | 0.800 | 0.7200 |
| F | 0.3581514 | 0.280 | 0.800 | 1.3500 |
| Na | 0.0259544 | 0.013 | 0.175 | 0.0875 |
| Mg | 0.0421061 | 0.048 | 0.175 | 0.0900 |
| Al | 0.0556577 | 0.046 | 0.325 | 0.1625 |
| Si | 0.0778369 | 0.076 | 0.450 | 0.4200 |
| P | 0.0998317 | 0.079 | 0.550 | 1.0600 |
| S | 0.1171670 | 0.069 | 0.650 | 0.7300 |
| Cl | 0.1426570 | 0.092 | 0.750 | 0.6900 |

^a s only.

TABLE 4: MCCM Coefficients

| method | c_H | c_1 | c_2 | c_3 | c_4 |
|------------|------------|---------|---------|---------|---------|
| BMC-QCISD | 1.06047423 | 1.10734 | 1.33058 | 0.92517 | 1.53093 |
| BMC-CCSD | 1.06047423 | 1.09791 | 1.33574 | 0.90363 | 1.55622 |
| BMC-CCSD-C | 1.06047423 | 1.09810 | 1.34076 | 0.89040 | 1.56497 |

new method replaces QCISD with CCSD, and replaces MP4(SDQ) with MP4(DQ). The new method, called BMC-CCSD, is illustrated in Figure 3. The four scaling coefficients are optimized for this method and are given in Table 4. The coefficients are defined by

$$\begin{aligned}
 E(\text{BMC-CCSD}) = & E(\text{HF}/6\text{-}31\text{B}(\text{d})) + \\
 & c_H \Delta(\text{HF}/\text{MG3}|6\text{-}31\text{B}(\text{d})) + c_1 \Delta(\text{MP2}|\text{HF}/6\text{-}31\text{B}(\text{d})) + \\
 & c_2 \Delta(\text{MP2}|\text{HF}/\text{MG3}|6\text{-}31\text{B}(\text{d})) + \\
 & c_3 \Delta(\text{MP4}(\text{DQ})|\text{MP2}/6\text{-}31\text{B}(\text{d})) + \\
 & c_4 \Delta(\text{CCSD}|\text{MP4}(\text{DQ})/6\text{-}31\text{B}(\text{d})) + E_{\text{SO}} \quad (9)
 \end{aligned}$$

BMC-QCISD and the BMC-CCSD methods use both the 6-31B-

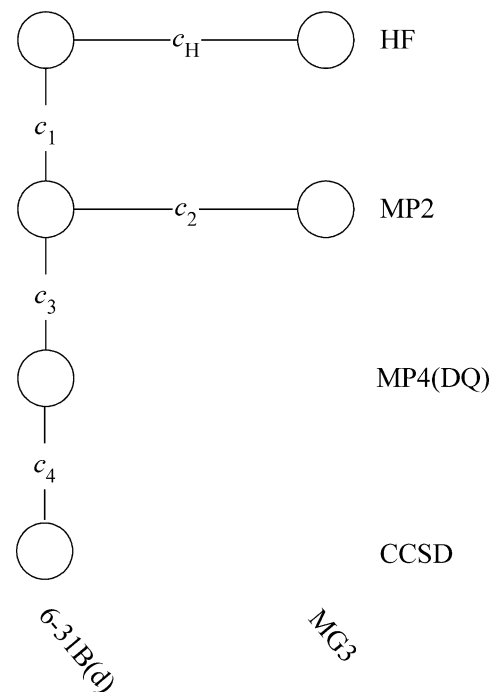

Figure 3. Coefficient tree for BMC-CCSD.

(d) basis set which uses Cartesian (6D) polarization functions and the MG3 basis set which uses spherical (5D,7F) polarization functions. To allow the BMC-CCSD method to be calculated using only Cartesian polarization functions, we also include the Cartesian variant BMC-CCSD-C where we replace the spherical harmonic d and f functions in MG3 with Cartesian (6D,10F) polarization functions. The scaling coefficients for this method are also in Table 4.

4. Results and Discussion

To compare the relative cost of most methods discussed, we quote the sum of the CPU times to calculate a single-point energy, single-point gradient, or single-point Hessian (as stated in each case) for the two molecules, 1-phosphinopropane and 2,2-dichloro-1-ethanol, with a single 500 MHz R14000 processor on a Silicon Graphics Origin 3800, normalized by dividing by the sum of the times for MP2/6-31G(2df,p) gradient calculations on the same two molecules with the same program on the same computer. In a few cases the times were computed on other computers but because they are normalized on the same computer on which they are computed, the times are comparable. The CPU times for CCSD gradients and Hessians were found using Gaussian03,²⁵ and all other times were calculated with the Gaussian98 electronic structure package.

First we comment on the new exponents for the 6-31B(d) basis set. Table 2 shows that for 13 out of 15 cases the sp exponent is lowered. This corresponds well with previous suggestions that the valence portion the 6-31G(d) basis set is not diffuse enough.^{66,67} The largest change in the d exponents is for P, where the polarization function gets much tighter; this too is in agreement with a previously noted⁶⁸ deficiency in the 6-31G(d) basis set. We note that the 6-31B(d) basis set, despite the fact that it was motivated by the desire to have better correlation energy balance¹¹ in MCCM calculations, was also found to have better performance than 6-31G(d) in correlated single-level calculations by wave function theory. Thus it seems that the new basis set represents a general improvement over the 6-31G(d) basis set. Table 5 give the errors for MP2, MP4(SDQ), QCISD, and CCSD using the 6-31G(d) and 6-31B(d) basis sets.

TABLE 5: Mean Unsigned Errors (kcal/mol) for Single-Level Calculations.

| quantity | item | MP2/ 6-31G(d) | MP2/ 6-31B(d) | MP4(SDQ)/ 6-31G(d) | MP4(SDQ)/ 6-31B(d) | QCISD/ 6-31G(d) | QCISD/ 6-31B(d) | CCSD/ 6-31G(d) | CCSD/ 6-31B(d) |
|----------|----------------------------|------------------|------------------|-----------------------|-----------------------|--------------------|--------------------|-------------------|-------------------|
| MUE | AE (error per bond) (604) | 8.16 | 7.78 | 11.35 | 11.05 | 11.57 | 11.31 | 13.14 | 11.56 |
| | barrier heights (42) | 6.88 | 7.24 | 6.98 | 7.17 | 5.93 | 6.12 | 6.05 | 6.24 |
| | electron affinities (35) | 23.92 | 14.24 | 23.63 | 13.76 | 24.45 | 14.43 | 24.35 | 14.27 |
| | ionization potentials (36) | 11.14 | 9.71 | 10.05 | 9.16 | 9.80 | 8.85 | 9.69 | 9.06 |
| | av error ^a | 12.53 | 9.74 | 13.00 | 10.29 | 12.94 | 10.18 | 13.31 | 10.28 |
| | weighted av ^b | 10.86 | 9.00 | 11.72 | 9.89 | 11.54 | 9.69 | 12.07 | 9.82 |

^a Average of rows 1–4. ^b One-third of first row plus one-third of second, one-sixth of third, and one-sixth of fourth.

TABLE 6: Mean Unsigned Errors (kcal/mol), Cost Scaling, and Single-Point Costs

| quantity | item | MC- QCISD/3 | BMC- QCISD | BMC- CCSD | BMC- CCSD-C | MCG3/3 | G3SX(MP2) //QM | G3SX(MP3) //QM | G3SX //QM |
|----------|----------------------------|-------------------|-------------------|-------------------|-------------------|-------------------|-------------------------|-------------------------|-------------------------|
| MUE | AE (error per bond) (604) | 0.56 | 0.49 | 0.42 | 0.43 | 0.35 | 0.73 | 0.31 | 0.28 |
| | max. error | 20.71 (BC) | 15.59 (BC) | 14.76 (BC) | 14.75 (BC) | 5.83 (MgO) | 7.04 (MgF) | 6.74 (MgF) | 6.38 (MgF) |
| | barrier heights (42) | 1.27 | 0.80 | 0.71 | 0.71 | 0.95 | 0.81 | 0.88 | 0.76 |
| | max. error | 3.53 ^d | 2.27 ^e | 1.76 ^f | 1.80 ^f | 3.35 ^d | 2.81 ^d | 2.40 ^d | 2.26 ^d |
| | electron affinities (35) | 1.91 | 1.30 | 1.28 | 1.28 | 1.55 | 2.05 | 1.42 | 1.24 |
| | max. error | 6.33 (Li) | 4.24 (OH) | 4.16 (OH) | 4.15 (OH) | 5.78 (Li) | 6.76 (Al ₃) | 5.49 (Al ₃) | 5.32 (Al ₃) |
| | ionization potentials (36) | 1.97 | 1.77 | 1.76 | 1.76 | 1.30 | 1.77 | 1.43 | 1.15 |
| | max. error | 5.74 (S) | 6.47 (FO) | 4.76 (FO) | 4.72 (FO) | 5.03 (Be) | 5.98 (Be) | 3.93 (S) | 3.08 (S) |
| | av error ^b | 1.43 | 1.09 | 1.04 | 1.04 | 1.04 | 1.34 | 1.01 | 0.86 |
| | weighted av ^c | 1.26 | 0.94 | 0.88 | 0.89 | 0.91 | 1.15 | 0.87 | 0.74 |
| cost | scaling | 6 | 6 | 6 | 6 | 7 | 7 | 7 | 7 |
| | energy | 1.9 | 1.9 | 2.0 | 2.0 | 3.3 | 5.3 | 8.1 | 13.5 |
| | gradient | 5.5 | 5.8 | 5.8 | 5.8 | 45 | 56 | 66 | 460 |
| | hessian | 140 | 150 | 150 | 150 | 2600 | 3200 | 3500 | 29000 |

^a All results in this table are for QCISD/MG3 geometries. For the three methods that are standardly defined to use other geometries, this is denoted “//QM”, whereas for other methods in this table, this footnote should be sufficient. ^b Average of rows 1–4. ^c One-third of first row plus one-third of second, one-sixth of third, and one-sixth of fourth. ^d PH₂ + H₂. ^e NH₂ + H₂O. ^f NH + C₂H₆.

For all four methods, the errors in AEs, IPs, and EAs are decreased going to the 6-31B(d) basis set. Also, in all four methods the error in BHs increases slightly. The average error over Database/4, averaged over these four methods decreases 22% going to the 6-31B(d) basis set. The 6-31B(d) basis performs well in terms of the experimental properties calculated in the present study, but it should be used with caution for predicting any properties for which it has not been tested. We note that the exponents of the new basis functions do not follow the typical patterns found in many basis sets, such as a monotonic increase in the exponent from left to right of the periodic table.

Next we consider the performance of the new MCCM methods. Table 6 shows that BMC-QCISD has a 24% lower average error than MC-QCISD/3. The error is lower in all categories in Table 6 when compared to MC-QCISD/3. BMC-CCSD further improves upon this and has a 27% lower average error than MC-QCISD/3. BMC-CCSD has a lower error than MCG3/3 for EAs and BHs, and slightly higher errors for IPs and AEs. At a glance, MCG3/3 might appear obsolete; however, it is still useful for those cases where one trusts the results more when they are computed by extrapolating from higher level components. This could be the case for unusual molecules. Compared to BMC-CCSD, G3SX(MP2)//QM is much more expensive and has higher error in all four categories, whereas G3SX(MP3)//QM and G3SX//QM have much higher cost and slightly lower error. If we use the weighted error (which puts less emphasis on electron affinities and ionization potentials), G3SX(MP3) has 1% lower error than BMC-CCSD, and G3SX has an error that is 15% lower. The version of BMC-CCSD

where we use only Cartesian polarization functions (BMC-CCSD-C) has approximately the same errors as the version that uses spherical harmonic functions for the larger basis.

The maximum errors (also shown in Table 6) are quite reasonable for barrier heights, electron affinities, and ionization potentials. However, the maximum errors in atomization energy per bond illustrate the limited accuracy of some MCCM methods for exotic systems. BMC-CCSD underestimates the bond energy of BC by 15 kcal/mol, whereas the four MCCM methods that contain at least one component calculation including triples contributions all have errors less than 5 kcal/mol for the same difficult system.

The combination of terms that comprise CCSD(T) have been shown to provide useful results for solving many chemical problems for systems including the atoms H–Ar. Although the combination of terms chosen to be included in CCSD(T) performs well for the first two rows, it can fail dramatically when applied to transition metal bonds and other systems that require a multireference description.^{69,70} Similarly, one should be cautious about using MCCM methods on systems which are very different from the systems tested.

To confirm that the results are reasonable, it is instructive to examine the individual terms in the MCCM expression more closely. As an example, we present such an analysis for BMC-CCSD, although similar conclusions can be drawn for all three new methods. In eq 9, the first, third, fifth, and sixth terms comprise the small basis set contributions to the BMC-CCSD energy, and this will be referred to as BMC-SB. In Table 7 we compare the correlation energy, singlet–triplet splitting, and electron affinity of CH₂ as calculated by FCI, BMC-CCSD, and

TABLE 7: Correlation Energy, Singlet–Triplet Splitting, and Electron Affinity of Methylene (kcal/mol)

| method | CH ₂ (³ B ₁) | CH ₂ (¹ A ₁) | CH ₂ ⁻ (² B ₁) | T _c | EA |
|---------------------|---|---|--|----------------|--------|
| HF/6-31B(d) | 0.00 | 0.00 | 0.00 | 30.20 | -41.94 |
| MP2/6-31B(d) | 52.28 | 62.30 | 70.35 | 20.18 | -23.87 |
| MP4(DQ)/6-31B(d) | 62.70 | 76.12 | 81.29 | 16.78 | -23.35 |
| CCSD/6-31B(d) | 63.68 | 78.37 | 82.29 | 15.50 | -23.33 |
| FCI/6-31B(d) | 64.84 | 80.51 | 84.18 | 14.53 | -22.60 |
| BMC-SB ^a | 68.21 | 84.23 | 88.53 | 14.18 | -21.62 |
| HF/MG3 | 0.00 | 0.00 | 0.00 | 28.21 | -23.56 |
| MP2/MG3 | 71.97 | 84.71 | 103.48 | 15.48 | 7.95 |
| BMC-CCSD | 94.50 | 114.15 | 132.76 | 8.44 | 15.8 |
| exp | | | | 9.35 | 14.0 |

^a Same as BMC-CCSD except c_H = c₂ = 0.

all the component calculations of BMC-CCSD. Although the coefficients in BMC-CCSD are optimized to simultaneously extrapolate both the basis set and the correlation energy, the BMC-SB energy is similar to the FCI/6-31B(d) energy. The BMC-SB calculated value for both the T_c and EA is very close to the FCI/6-31B(d) result, although the BMC-SB result is closer to experiment in both cases. In the three systems examined, the BMC-SB correlation energy is 5.0% ± 0.3% larger than FCI. This appears very reasonable because as mentioned before the BMC-SB group of terms includes some additional correlation energy associated with the extrapolation to complete configuration interaction. Note that the BMC-SB group of terms does not attempt to extrapolate to the FCI with the 6-31B(d) basis set. It is only part of an extrapolation to full configuration interaction with a complete basis.

As mentioned earlier in this article as well as previous work,^{6,12} extrapolations that include at least one component at the QCISD (or higher) level perform significantly better than those with only lower levels of correlation. A simple explanation for this can be seen by the convergence of the correlation energy for the three systems in Table 7. Valence MP2 perturbation theory accounts for only 80% of the FCI correlation energy compared to 98% captured by QCISD or CCSD (the latter is shown in Table 7). It is intuitively obvious then that methods using QCISD or CCSD and extrapolating the remaining 2% of the correlation energy will tend to have greater accuracy than methods attempting to extrapolate 20%.

Faced with a daunting array of extrapolation procedures available,^{1–7,12,14,26,71–94} some researchers simply choose an additive approach to estimate a large-basis-set ab initio calculation. In this approach, one performs a large basis set calculation such as MP2/MG3 and adds a high-level unscaled correlation contribution such as CCSD/6-31B(d)–MP2/6-31B(d). The sum of these two terms is an attempt to approximate a CCSD/MG3 calculation and it is equivalent to setting all the coefficients of the BMC-CCSD expression in eq 9 to 1.0. For the tests in Table 7, this unscaled method has errors of 1.45 and 5.5 kcal/mol compared with the BMC-CCSD errors of 0.91 and 1.8 kcal/mol. The unscaled method is far less accurate than BMC-CCSD; however, the cost is essentially the same. For the test in Table 5, this unscaled method has an average error of 3.89 kcal/mol and a weighted average of 3.93 kcal/mol. Thus scaling is preferable to addition.

5. Summary

The new BMC-QCISD and BMC-CCSD methods presented in this article are shown to be very efficient new MCCM methods. The BMC-CCSD method is especially efficient, and BMC-CCSD results can be easily calculated with many electronic structure packages.

The 6-31B(d) basis set is available in several formats at the website: <http://comp.chem.umn.edu/basissets>, and a program, MULTILEVEL, that serves as a front end for ACESII,⁹⁵ GAMESS,⁹⁶ or *Gaussian*^{24,25} to carry out the methods in Table 5 is also available on the website <http://comp.chem.umn.edu/multilevel>.

Acknowledgment. This work was supported in part by the U.S. Department of Energy, Office of Basic Energy Sciences.

Supporting Information Available: Tables of ionization potentials and electron affinities, atomization energies, and barrier heights. This material is available free of charge via the Internet at <http://pubs.acs.org>.

References and Notes

- Tratz, C. M.; Fast, P. L.; Truhlar, D. G. *PhysChemComm* **1999**, 2, 14.
- Fast, P. L.; Corchado, J.; Sanchez, M. L.; Truhlar, D. G. *J. Phys. Chem. A* **1999**, 103, 3139.
- Fast, P. L.; Sanchez, M. L.; Corchado, J. C.; Truhlar, D. G. *J. Chem. Phys.* **1999**, 110, 11679.
- Fast, P. L.; Sanchez, M. L.; Truhlar, D. G. *Chem. Phys. Lett.* **1999**, 306, 407.
- Curtiss, L. A.; Raghavachari, K.; Redfern, P. C.; Pople, J. A. *J. Chem. Phys.* **2000**, 112, 1125.
- Lynch, B. J.; Truhlar, D. G. *J. Phys. Chem. A* **2003**, 107, 3898.
- Curtiss, L. A.; Redfern, P. C.; Raghavachari, K.; Pople, J. A. *J. Chem. Phys.* **2001**, 114, 108.
- Møller, C.; Plesset, M. S. *Phys. Rev.* **1934**, 46, 618.
- Pople, J. A.; Head-Gordon, M.; Raghavachari, K. *J. Chem. Phys.* **1987**, 87, 5968.
- Lynch, B. J.; Zhao, Y.; Truhlar, D. G. *J. Phys. Chem. A* **2003**, 107, 1384.
- Gordon, M. S.; Truhlar, D. G. *Int. J. Quantum Chem.* **1987**, 31, 81.
- Fast, P. L.; Truhlar, D. G. *J. Phys. Chem. A* **2000**, 104, 6111.
- Gordon, M. S.; Truhlar, D. G. *J. Am. Chem. Soc.* **1986**, 108, 5412.
- Fast, P. L.; Corchado, J. C.; Sanchez, M. L.; Truhlar, D. G. *J. Phys. Chem. A* **1999**, 103, 5129.
- Mebel, A. M.; Morokuma, K.; Lin, M. C. *J. Chem. Phys.* **1995**, 103, 7414.
- Hrusak, J.; Ten-No, S.; Iwata, S. *J. Chem. Phys.* **1997**, 106, 7185.
- Boehme, M.; Frenking, G. *Chem. Phys. Lett.* **1994**, 224, 195.
- Bauschlicher, C. W., Jr.; Partridge, H. *J. Chem. Phys.* **1995**, 103, 1788.
- Hehre, W. J.; Radom, L.; Schleyer, P. v. R.; Pople, J. A. *Ab Initio Molecular Orbital Theory*; Wiley: New York, 1986.
- Raghavachari, K.; Trucks, G. W.; Pople, J. A.; Head-Gordon, M. *Chem. Phys. Lett.* **1989**, 157, 479.
- Knowles, P. J.; Handy, N. C. *Chem. Phys. Lett.* **1984**, 111, 315.
- Knowles, P. J.; Handy, N. C. *Comput. Phys. Comm.* **1989**, 54, 75.
- Werner, H.-J.; Knowles, P. J.; Lindh, R.; Schütz, M.; Celani, P.; Korona, T.; Manby, F. R.; Rauhut, G.; Amos, R. D.; Bernhardsson, A.; Berning, A.; Cooper, D. L.; Deegan, M. J. O.; Dobbyn, A. J.; Eckert, F.; Hampel, C.; Hetzer, G.; Lloyd, A. W.; McNicholas, S. J.; Meyer, W.; Mura, M. E.; Nicklass, A.; Palmieri, P.; Pitzer, R.; Schumann, U.; Stoll, H.; Stone, A. J.; Tarroni, R.; Thorsteinsson, T. MOLPRO 2002.1, Birmingham, U.K., 2003.
- Frisch, M. J.; Trucks, G. W.; Schlegel, H. B.; Scuseria, G. E.; Robb, M. A.; Cheeseman, J. R.; Zakrzewski, V. G.; Montgomery, J. A.; Stratmann, R. E.; Burant, J. C.; Dapprich, S.; Millam, J. M.; Daniels, A. D.; Kudin, K. N.; Strain, M. C.; Farkas, O.; Tomasi, J.; Barone, V.; Cossi, M.; Cammi, R.; Mennucci, B.; Pomelli, C.; Adamo, C.; Clifford, S.; Ochterski, J.; Petersson, G. A.; Ayala, P. Y.; Cui, Q.; Morokuma, K.; Malick, D. K.; Rabuck, A. D.; Raghavachari, K.; Foresman, J. B.; Cioslowski, J.; Ortiz, J. V.; Baboul, A. G.; Stefanov, B. B.; Liu, G.; Liashenko, A.; Piskorz, P.; Komaromi, I.; Gomperts, R.; Martin, R. L.; Fox, D. J.; Keith, T.; Al-Laham, M. A.; Peng, C. Y.; Nanayakkara, A.; Challacombe, M.; Gill, P. M. W.; Johnson, B. G.; Chen, W.; Wong, M. W.; Andres, J. L.; Gonzalez, C.; Head-Gordon, M.; Replogle, E. S.; Pople, J. A. *Gaussian98*; Gaussian, Inc.: Pittsburgh, PA, 2001.
- Frisch, M. J.; Trucks, G. W.; Schlegel, H. B.; Scuseria, G. E.; Robb, M. A.; Cheeseman, J. R.; Montgomery, J. J. A.; Vreven, T.; Kudin, K. N.; Burant, J. C.; Millam, J. M.; Iyengar, S. S.; Tomasi, J.; Barone, V.; Mennucci, B.; Cossi, M.; Scalmani, G.; Rega, N.; Petersson, G. A.; Nakatsuji, H.; Hada, M.; Ehara, M.; Toyota, K.; Fukuda, R.; Hasegawa, J.; Ishida, M.; Nakajima, T.; Honda, Y.; Kitao, O.; Nakai, H.; Klene, M.; Li, X.; Knox, J. E.; Hratchian, H. P.; Cross, J. B.; Adamo, C.; Jaramillo, J.; Gomperts, R.; Stratmann, R. E.; Yazyev, O.; Austin, A. J.; Cammi, R.

- Pomelli, C.; Ochterski, J. W.; Ayala, P. Y.; Morokuma, K.; Voth, G. A.; Salvador, P.; Dannenberg, J. J.; Zakrzewski, V. G.; Dapprich, S.; Daniels, A. D.; Strain, M. C.; Farkas, O.; Malick, D. K.; Rabuck, A. D.; Raghavachari, K.; Foresman, J. B.; Ortiz, J. V.; Cui, Q.; Baboul, A. G.; Clifford, S.; Cioslowski, J.; Stefanov, B. B.; Liu, G.; Liashenko, A.; Piskorz, P.; Komaromi, I.; Martin, R. L.; Fox, D. J.; Keith, T.; Al-Laham, M. A.; Peng, C. Y.; Nanayakkara, A.; Challacombe, M.; Gill, P. M. W.; Johnson, B.; Chen, W.; Wong, M. W.; Gonzalez, C.; Pople, J. A. *Gaussian03*, revision B.01; Gaussian, Inc.: Pittsburgh, PA, 2004.
- (26) Curtiss, L. A.; Raghavachari, K.; Redfern, P. C.; Rassolov, V.; Pople, J. A. *J. Chem. Phys.* **1998**, *109*, 7764.
- (27) Curtiss, L. A.; Redfern, P. C.; Raghavachari, K.; Rassolov, V.; Pople, J. A. *J. Chem. Phys.* **1999**, *110*, 4703.
- (28) Curtiss, L. A.; Raghavachari, K.; Redfern, P. C.; Pople, J. A. *J. Chem. Phys.* **1997**, *106*, 1063.
- (29) Lias, S. G. Ionization Energy Evaluations. In *NIST Standard Reference Database Number 69*; Linstrom, P. J., Mallard, W. G., Eds.; National Institute of Standards and Technology: Gaithersburg, MD, 2003.
- (30) Herzberg, K. G. *Molecular Spectra and Molecular Structure. I*, 2nd ed.; D. van Nostrand: Princeton, 1950.
- (31) Harrington, J. E.; Weisshaar, J. C. *J. Chem. Phys.* **1990**, *93*, 854.
- (32) Zhang, Z.; Kuo, S.-C.; Klemm, R. B.; Monks, P. S.; Stief, L. J. *Chem. Phys. Lett.* **1994**, *229*, 377.
- (33) Dyke, J. M.; Kirby, C.; Morris, A.; Gravenor, B. W. J.; Klein, R.; Rosmus, P. *Chem. Phys.* **1984**, *88*, 289.
- (34) Kappes, M. M.; Schumacher, E. *Surf. Sci.* **1985**, *156*, 1.
- (35) Chase, M. W., Jr. *J. Phys. Chem. Ref. Data* **1998**, *9*, 1.
- (36) Rienstra-Kiracofe, J. C.; Tschumper, G. S.; Schaefer, H. F., III.; Nandi, S.; Ellison, G. B. *Chem. Rev.* **2002**, *102*, 231.
- (37) Gutsev, G. L.; Jena, P.; Bartlett, R. J. *J. Chem. Phys.* **1999**, *110*, 2928.
- (38) Villalta, P. W. Anion Photoelectron Spectroscopy of Metallic Species: First Row Transition Metal Monocarbonyls and Aluminum Trimer, University of Minnesota, 1993.
- (39) Zittel, P. F.; Lineberger, W. C. *J. Chem. Phys.* **1976**, *65*, 1236.
- (40) Bauschlicher, C. W., Jr.; Langhoff, S. R.; Partridge, H. *J. Chem. Phys.* **1992**, *96*, 1240.
- (41) Langhoff, S. R.; Bauschlicher, C. W., Jr. *J. Chem. Phys.* **1991**, *95*, 5882.
- (42) Martin, J. M. L.; Taylor, P. R. *J. Chem. Phys.* **1994**, *100*, 9002.
- (43) Huber, K. P.; Herzberg, G. *Molecular Spectra and Molecular Structure, 4: Constants of Diatomic Molecules*; 1979.
- (44) Sullivan, M. B.; Iron, M. A.; Redfern, P. C.; Martin, J. M. L.; Curtiss, L. A.; Radom, L. *J. Phys. Chem. A* **2003**, *107*, 5617.
- (45) Hildenbrand, D. L.; Murad, E. *J. Chem. Phys.* **1966**, *44*, 1524.
- (46) Bauschlicher, C. W., Jr.; Langhoff, S. R.; Partridge, H. *J. Chem. Phys.* **1986**, *84*, 901.
- (47) de Galan, L. *Physica (The Hague)* **1965**, *31*, 1286.
- (48) Gurvich, L. V.; Veyts, I. V.; Alcock, C. B.; Iorish, V. S., Eds. *Thermodynamic Properties of Individual Substances*; Boca Raton, FL, 1994; Vol. 3.
- (49) Esseffar, M.; Luna, A.; Mo, O.; Yanez, M. *J. Phys. Chem.* **1994**, *98*, 8679.
- (50) Naulin, C.; Costes, M. *Chem. Phys. Lett.* **1999**, *310*, 231.
- (51) Murad, E. *J. Chem. Phys.* **1981**, *75*, 4080.
- (52) Mason, M. A.; Lehmann, K. K. *J. Chem. Phys.* **1993**, *98*, 5184.
- (53) Fu, Z.; Lemire, G. W.; Bishea, G. A.; Morse, M. D. *J. Chem. Phys.* **1990**, *93*, 8420.
- (54) Partridge, H.; Langhoff, S. R.; Bauschlicher, C. W., Jr. *J. Chem. Phys.* **1988**, *88*, 6431.
- (55) Rostas, J.; Shafizadeh, N.; Taieb, G.; Bourguignon, B.; Prisant, M. *G. Chem. Phys.* **1990**, *142*, 97.
- (56) Drowart, J.; Myers, C. E.; Szwarc, R.; Vander Auwera-Mahieu, A.; Uy, O. M. *J. Chem. Soc., Faraday Trans. 2: Mol. Chem. Phys.* **1972**, *68*, 1749.
- (57) Atkinson, R.; Baulch, D. L.; Cox, R. A.; Hampson, R. F., Jr.; K. J. A.; Rossi, M. J.; Troe, J. *J. Phys. Chem. Ref. Data* **2000**, *29*, 167.
- (58) Csaszar, A. G.; Leininger, M. L.; Szalay, V. *J. Chem. Phys.* **2003**, *118*, 10631.
- (59) Jensen, P.; Bunker, P. R. *J. Chem. Phys.* **1988**, *89*, 1327.
- (60) Kirkbride, F. W.; Davidson, F. G. *Nature* **1954**, *174*, 79.
- (61) Ashworth, S. H.; Brown, J. M. *J. Mol. Spectrosc.* **1992**, *153*, 41.
- (62) Lynch, B. J.; Zhao, Y.; Truhlar, D. G. <http://comp.chem.umn.edu/database>, 2004.
- (63) Cizek, J. *Adv. Chem. Phys.* **1969**, *14*, 35.
- (64) Bartlett, R. J. *J. Phys. Chem.* **1989**, *93*, 1697.
- (65) Scuseria, G. E.; Schaefer, H. F., III. *J. Chem. Phys.* **1989**, *90*, 3700.
- (66) Frisch, M. J.; Pople, J. A.; Binkley, J. S. *J. Chem. Phys.* **1984**, *80*, 3265.
- (67) Del Bene, J. E.; Aue, D. H.; Shavitt, I. *J. Am. Chem. Soc.* **1992**, *114*, 1631.
- (68) Wesolowski, S. S.; Brinkmann, N. R.; Valeev, E. F.; Schaefer, H. F., III.; Repasky, M. P.; Jorgensen, W. L. *J. Chem. Phys.* **2002**, *116*, 112.
- (69) Bauschlicher, C. W., Jr.; Partridge, H. *Chem. Phys. Lett.* **1994**, *231*, 277.
- (70) Piecuch, P.; Kowalski, K.; Pimienta, I. S. O.; McGuire, M. J. *Int. Rev. Phys. Chem.* **2002**, *21*, 527.
- (71) Fast, P. L.; Sanchez, M. L.; Truhlar, D. G. *J. Chem. Phys.* **1999**, *111*, 2921.
- (72) Fast, P. L.; Schultz, N. E.; Truhlar, D. G. *J. Phys. Chem. A* **2001**, *105*, 4143.
- (73) Truhlar, D. G. Basis-set extrapolation. In *Chem. Phys. Lett.* **1998**, *294*, 45.
- (74) Brown, F. B.; Truhlar, D. G. *Chem. Phys. Lett.* **1985**, *117*, 307.
- (75) Curtiss, L. A.; Raghavachari, K.; Trucks, G. W.; Pople, J. A. *J. Chem. Phys.* **1991**, *94*, 7221.
- (76) Curtiss, L. A.; Raghavachari, K.; Pople, J. A. *J. Chem. Phys.* **1993**, *98*, 1293.
- (77) Curtiss, L. A.; Raghavachari, K.; Pople, J. A. *J. Chem. Phys.* **1995**, *103*, 4192.
- (78) Curtiss, L. A.; Raghavachari, K.; Redfern, P. C.; Baboul, A. G.; Pople, J. A. *Chem. Phys. Lett.* **1999**, *314*, 101.
- (79) Curtiss, L. A.; Redfern, P. C.; Raghavachari, K.; Pople, J. A. *Chem. Phys. Lett.* **2002**, *359*, 390.
- (80) Curtiss, L. A.; Redfern, P. C.; Rassolov, V.; Kedziora, G.; Pople, J. A. *J. Chem. Phys.* **2001**, *114*, 9287.
- (81) Curtiss, L. A.; Redfern, P. C.; Smith, B. J.; Radom, L. *J. Chem. Phys.* **1996**, *104*, 5148.
- (82) Allen, W. D.; Schuurman, M.; Wheeler, S.; Kenny, J. P.; Schaefer, H. F. In pursuit of subchemical accuracy in computational thermochemistry. Abstracts of Papers, 228th ACS National Meeting, Philadelphia, PA, United States, August 22–26, 2004, 2004.
- (83) Gonzales, J. M.; Pak, C.; Cox, R. S.; Allen, W. D.; Schaefer, H. F., III.; Csaszar, A. G.; Tarczay, G. *Chem.—Eur. J.* **2003**, *9*, 2173.
- (84) Valeev, E. F.; Allen, W. D.; Hernandez, R.; Sherrill, C. D.; Schaefer, H. F., III. *J. Chem. Phys.* **2003**, *118*, 8594.
- (85) Kenny, J. P.; Allen, W. D.; Schaefer, H. F., III. *J. Chem. Phys.* **2003**, *118*, 7353.
- (86) Csaszar, A. G.; Tarczay, G.; Leininger, M. L.; Polyansky, O. L.; Tennyson, J.; Allen, W. D. *NATO Sci. Ser., II: Math., Phys. Chem.* **2001**, *20*, 317.
- (87) Valeev, E. F.; Allen, W. D.; Schaefer, H. F., III.; Csaszar, A. G. *J. Chem. Phys.* **2001**, *114*, 2875.
- (88) Leininger, M. L.; Allen, W. D.; Schaefer, H. F., III.; Sherrill, C. D. *J. Chem. Phys.* **2000**, *112*, 9213.
- (89) Csaszar, A. G.; Allen, W. D.; Schaefer, H. F., III. *J. Chem. Phys.* **1998**, *108*, 9751.
- (90) Schuurman, M. S.; Muir, S. R.; Allen, W. D.; Schaefer, H. F., III. *J. Chem. Phys.* **2004**, *120*, 11586.
- (91) Schuurman Michael, S.; Muir Steven, R.; Allen Wesley, D.; Schaefer Henry, F., 3rd. *J. Chem. Phys.* **2004**, *120*, 11586.
- (92) Martin, J. M. L.; de Oliveira, G. *J. Chem. Phys.* **1999**, *111*, 1843.
- (93) Martin, J. M. L.; Uzan, O. *Chem. Phys. Lett.* **1998**, *282*, 16.
- (94) Boese, A. D.; Oren, M.; Atasoylu, O.; Martin, J. M. L.; Kallay, M.; Gauss, J. *J. Chem. Phys.* **2004**, *120*, 4129.
- (95) Stanton, J. F.; Gauss, J.; Watts, J. D.; Nooijen, M.; Oliphant, N.; Perera, S. A.; Szalay, P. G.; Lauderdale, W. J.; Kucharski, S. A.; Gwaltney, S. R.; Beck, S.; Balková, A.; Bernholdt, D. E.; Baeck, K. K.; Rozyczko, P.; Sekino, H.; Hober, C.; Bartlett, R. J. ACESII, 2004.
- (96) Schmidt, M. W.; Baldrige, K. K.; Boatz, J. A.; Elbert, S. T.; Gordon, M. S.; Jensen, J. H.; Koseki, S.; Matsunaga, N.; Nguyen, K. A.; et al. *J. Comput. Chem.* **1993**, *14*, 1347.